

## SKX 13/10

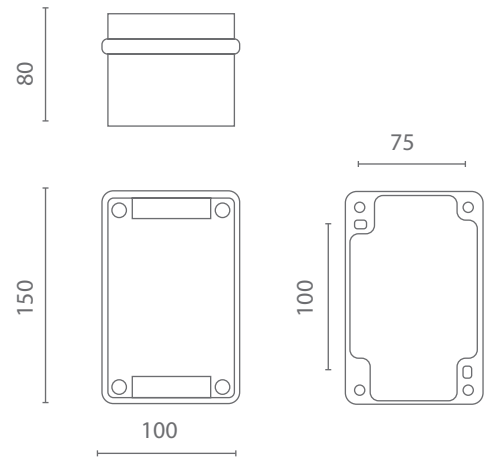

## Składa się z | Consist of

Łącznik SMS 03/1 | Switch SMS03/1

Oznaczenie SMO 17/1 | Marking SMO 17/1

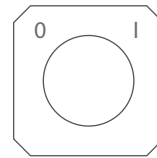
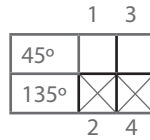
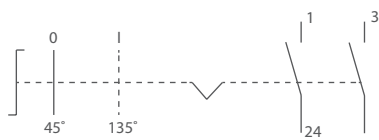

1.39

## Łącznik Ex

II 2G Ex de IIC T6  
II 2D tD A21 IP66 T80°C

Obudowa: poliestr wzmocniony włóknem szklanym  
 Pokrywka: poliestr wzmocniony włóknem szklanym, zintegrowana uszczelka wykonana z termoplastycznego elastomeru, 4 śruby M5 ze stali nierdzewnej

Dławnica:	1xM25	Średnica przew.:	ø6-15mm
Napięcie znam. izolacji:	690V	Napięcie znam.:	250V AC
Prąd znamionowy:	16A		

IP:	66	IK:	08
-----	----	-----	----

Certyfikat:	CESI 13 ATEX 017X
-------------	-------------------

## Ex switch

II 2G Ex de IIC T6  
II 2D tD A21 IP66 T80°C

Housing: poliestr reinforced with fibre glass  
 Cover: poliestr reinforced with fibre glass, integrated thermoplastic elastomer gasket, four stainless steel M5 screws

Cable gland:	1xM25	Cable diameter:	ø6-15mm
Insulation rated voltage:	690V	Rated voltage:	250V AC
Rated current:	16A		

IP:	66	IK:	08
-----	----	-----	----

Certificate:	CESI 13 ATEX 017X
--------------	-------------------